

## Shangyu Groupstar Electric Appliance Co., Ltd.

January 18, 2013

RDW rijksdienst voor het wegverkeer  
Certification and Supervision  
Europaweg 205  
2700 AT Zoetermeer  
The Netherlands

Subject for ECE-type approval

Dear Sir:

We hereby apply for type approval according to:

Function	ECE approval number	EEC approval number
Rear direction indicator	E4-6R-0117259	---
Stop & rear position lamp	E4-7R-0217259	---

Trade name or trade mark

: 

Manufacturer's name for type of device

: GS-LTL2010

Name and address of manufacturer

: Shangyu Groupstar Electric Appliance Co., Ltd.  
Wufu Industrial Park, Shangyu City,  
Zhejiang Province, P.R. China

We herewith declare that we have not applied and will not apply for approval with another Contracting Party of the ECE for the same type of product. Nor has any other member state granted a corresponding approval.

Sincerely

Signature:



Name: Mr. Xie Xinmiao / General Manager





THE NETHERLANDS  
(N E D E R L A N D)



COMMUNICATION

Concerning <sup>(1)</sup>:

- approval granted
- ~~approval extended~~
- ~~approval refused~~
- ~~approval withdrawn~~
- ~~production definitely discontinued~~

of a type of device pursuant to Regulation number 6.

Approval number: E4-6R-0117259

Extension number: 00

Approval mark:

2a R1-S1  
01 02  
  
17259

- |    |  |   |  |
|----|--|---|--|
| 1. | Trade name or mark of the device                                     | : |                                    |
| 2. | Manufacturer's name for the type of device                           | : | GS-LTL2010   |
| 3. | Manufacturer's name and address                                      | : | Shangyu Groupstar Electric Appliance Co., Ltd.<br>Wufu Industrial Park, Shangyu City,<br>Zhejiang Province, P.R. China |
| 4. | If applicable, name and address of the manufacturer's representative | : | ---  |
| 5. | Submitted for approval on  | : | January 18, 2013   |
| 6. | Technical service responsible for conducting approval tests          | : | TÜV Rheinland Kraftfahrt GmbH<br>Technologiezentrum Verkehrssicherheit<br>Am Grauen Stein,<br>D-51105 Köln (Poll)      |
| 7. | Date of test report issued by that service                           | : | February 3, 2013   |
| 8. | Number of test report issued by that service                         | : | 87-R6-141/13   |



9. Concise description
- Category : ~~1, 1a, 1b, 2a, 2b, 5, 6~~<sup>(2)</sup>
- Number, category : 7 LEDs, non-replaceable light sources
- Voltage and wattage : 12V, 1.3W
- Light source module specific identification code : not applicable
- Only for installation on M1 and/or N1 category vehicles : ~~yes/no~~<sup>(1)</sup>
- Only for limited mounting height of equal to or less than 750 mm above the ground : ~~yes/no~~<sup>(1)</sup>
- Geometrical conditions of installation and relating variations, if any : not applicable
- Application of an electronic light source control gear/variable intensity control (a) being part of the lamp : ~~yes/no~~<sup>(1)</sup>
- (b) being not part of the lamp : ~~yes/no~~<sup>(1)</sup>
- Input voltage(s) supplied by an electronic light source control gear/variable intensity control : not applicable
- Electronic light source control gear/variable intensity control manufacturer and identification number (when the light source control gear is part of the lamp but is not included into the lamp body) : not applicable
- Variable luminous intensity : ~~yes/no~~<sup>(1)</sup>
10. Position of the approval mark : on the lens
11. Reason(s) for extension (if applicable) : ---
12. Approval : granted/~~extended/refused/withdrawn~~<sup>(1)</sup>
13. Place : Zoetermeer
14. Date : 25-FEB-2013
15. Signature :
16. The list of documents deposited with the Administrative Service which has granted approval is annexed to this communication and may be obtained on request.  
 -Information document  
 -Test report

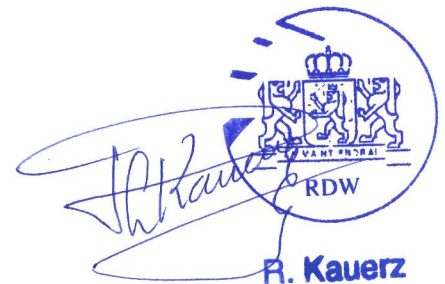



<sup>(1)</sup> Strike out what does not apply.

<sup>(2)</sup> For direction indicator lamps of categories 1, 1a, 1b, 2a and 2b, information regarding the signal according to paragraph 6.4.2.

Application date : January 18, 2013

## 1. Specification data

Type		<b>GS-LTL2010</b>		
Function		Rear Direction Indicator	Rear Position Lamp	Stop Lamp
Emitted color		Amber	Red	Red
Rated	Voltage	12V (Input range: 10V – 30V)		
	Wattage	1.3W	0.4W	1.4W
Applicable Regulation (ECE)		R6.01 Category 2a	R7.02 Category R1-S1	
Number and category of filament lamp(light source)		Non-replaceable light source		
		7LEDs	7LEDs	
Location of marking	Rated Voltage and Wattage	Marked on Housing		
	Trade mark	 	Marked on Lens	
	Approval mark	Marked on Lens		
Special supply voltage		Not applicable		
Application of additional supply system		Yes/ No		
Light source module		Yes/ No		

## 2. Construction and material

Construction	Material	Remarks
Outer lens	PC	Direction: amber color Rear position & stop: red color
Housing	ABS	-
Electrical wiring	Copper covered with insulation	-

3. Name and address of manufacturer : Shangyu Groupstar Electric Appliance Co., Ltd.  
Wufu Industrial Park, Shangyu City,  
Zhejiang Province, P.R. China

4. Name and address of representative of manufacturer : Not applicable

This information document consists of 3 pages.



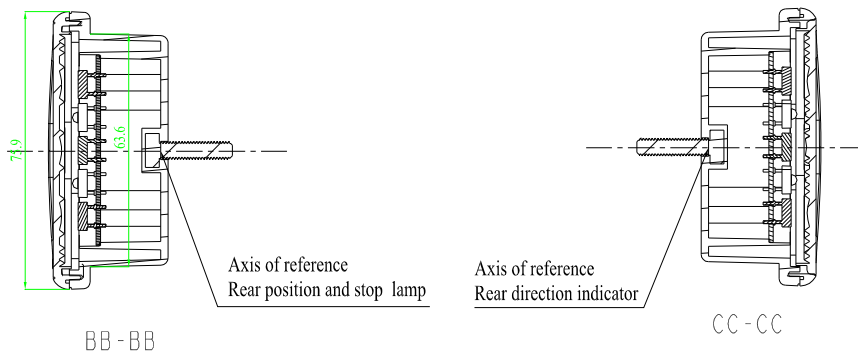
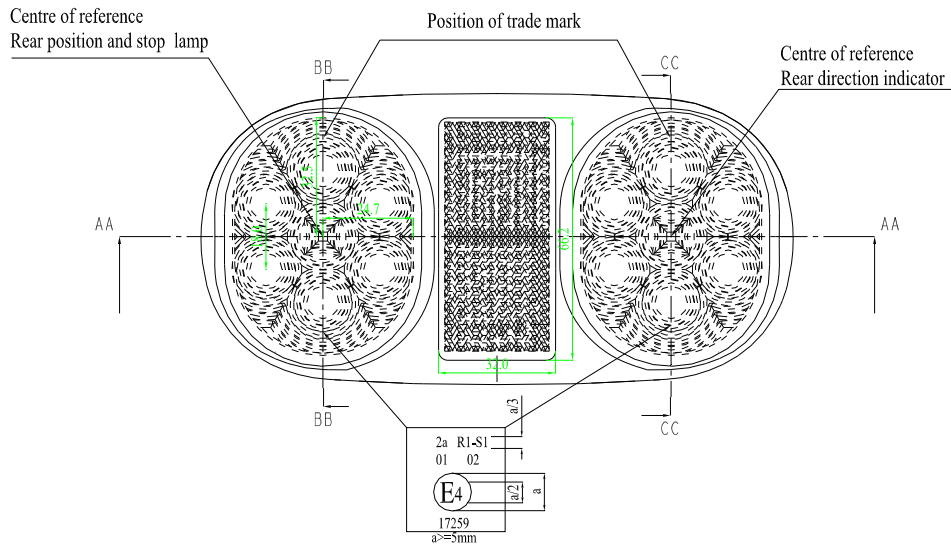
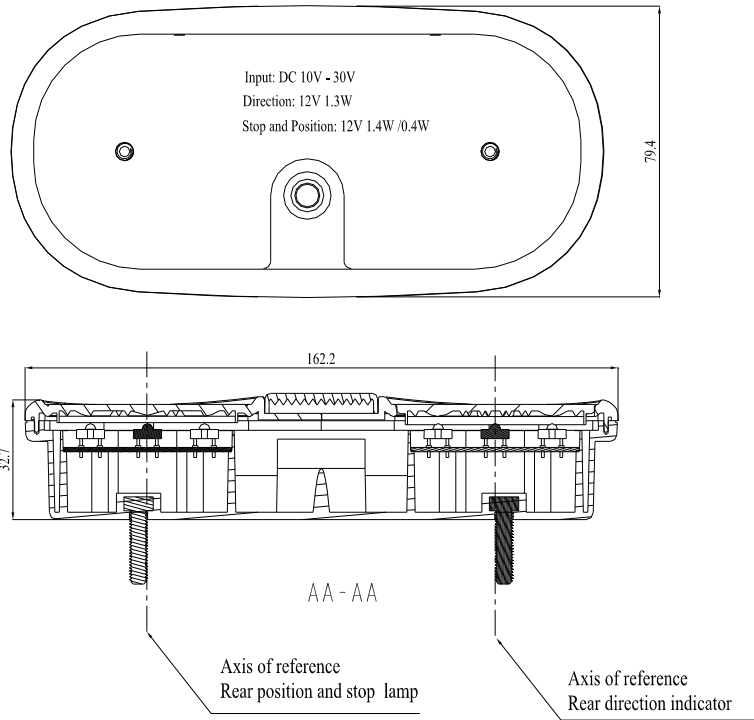

**CIRCUIT DIAGRAM**

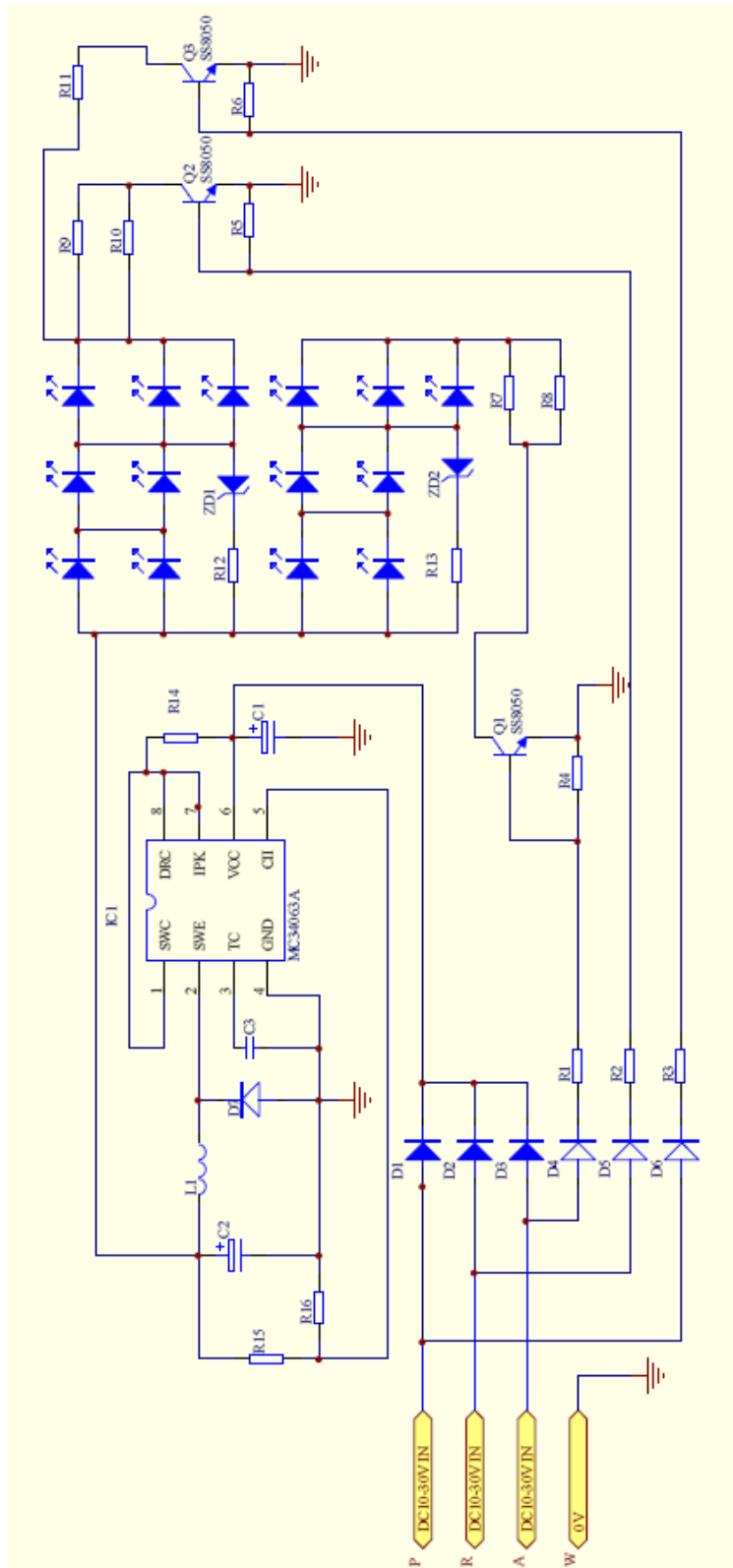

Non-replaceable light source (Input range: 10V – 30V)  
 Stop and rear position lamp: 7LEDs, 12V 1.4W/0.4W  
 Rear direction indicator: 7LEDs, 12V 1.3W



Manufacturer : Shangyu Groupstar Electric Appliance Co., Ltd.  
Type : GS-LTL2010

## TEST REPORT

according to ECE-Regulation

**Uniform provisions concerning the approval of direction indicators  
For power-driven vehicles and their trailers**

**ECE-R6**

including all amendments until

**series of Amendments: 01  
Supplement 22**

Previously granted	
ECE - certificate	: ---

Structure of report:

0. general information
1. Test object(s) and general test information
2. Test minutes
3. Remarks concerning tested object(s)
4. Appendices
5. Statement of conformity

Manufacturer : Shangyu Groupstar Electric Appliance Co., Ltd.  
 Type : GS-LTL2010

**0. General information**

- 0.1. Trademark or trade name of the lamp : 
- 0.2. Manufacturer's name for the type of the lamp : GS-LTL2010
- 0.3. Name and address of the manufacturer : Shangyu Groupstar Electric Appliance Co., Ltd.  
 Wufu Industrial Park, Shangyu City,  
 Zhejiang Province, P.R. China
- 0.4. Name and address of manufacturer's authorized representative : not applicable
- 0.5. No. of information folder : GS-LTL2010-00  
 date of issue : January 18, 2013  
 date of last amendment : ---

**1. Test object(s) and general test information**

- 1.1. Test object(s)
  - identification number : ---
  - version : ---
  - Remark : Non-replaceable light sources, 7 LEDs
- 1.2. General test information
  - 1.2.1. Order issued by (if different from manufacturer) : ---
  - 1.2.2. Test object / test vehicle received on : not applicable
  - 1.2.3. Test date : February 2, 2013
  - 1.2.4. Test site : Automotive Component Testing Center of Ningbo  
 No. 99, Jingu South Road, Yinzhou Investment &  
 Business Incubation, 315104, Ningbo,  
 P.R. China
  - 1.2.5. Remark : The results of the test refer exclusively to the object(s)  
 mentioned under point 1.1 of this report.



Manufacturer : Shangyu Groupstar Electric Appliance Co., Ltd.  
 Type : GS-LTL2010

2. Test minutes

- 2.1. Test facilities : The test facilities are in compliance with the requirements of the regulation.
  
- 2.2. Test results : ~~The type has been examined according to the amendments mentioned in appendix O.~~  
  
~~An actual test of the type was not required. The results of the previous tests are still valid.~~

Markings : The trade mark is marked clearly legible and indelible on the lens ~~and on the housing~~ of the lamp.

The rated voltage and rated wattage is clearly legible and indelible marked ~~on the lens and~~ on the housing of the lamp.

Space for the approval mark and for additional symbols is provided on the lens (the lens can not be separated from the housing).
  
- 2.3. General specifications : The lamps are designed and made that under normal use their satisfactory operation is ensured and they retain the required characteristics.

The colour of the light emitted is within the limits of the coordinates for Amber as prescribed in Annex 5 of the Regulation.

  
- 2.4. Photometric tests : The light intensity was measured after 1 minute burning period and after 30 minutes burning in reference axis. The distribution of the light intensity after 1 minute burning period was calculated using the ratio of the two described measurements. The light intensity and its distribution are in compliance with the requirement after 1 minute burning period and after 30 minutes burning period.

The light distribution angles and levels of intensity have been measured in accordance with Annex 4 of the Regulation, based on the manufacturer's indication of the centre of reference and axis of reference.

The single lamp containing more than one light source complies with the minimum intensity required when any one light source has failed.

Manufacturer : Shangyu Groupstar Electric Appliance Co., Ltd.  
 Type : GS-LTL2010

Results of photometric tests of the **Rear direction indicator lamp, category 2a**

measured after 1 minute burning period when all light sources lit

	light intensity of the lamps in reference axis [cd]	allowable maximum	required minimum
sample no. 1	112.5	500	50
sample no. 2	102.9	500	50

measured after 30 minutes burning period when all light sources lit

distribution of the intensity of the lamps in [cd]								
horizontal angle		L20°	L10°	L5°	V	R5°	R10°	R20°
vertical angle required minimum intensity	U10°	-	-	10	-	10	-	-
	U5°	5	10	-	35	--	10	5
	H	-	17.5	45	50	45	17.5	-
	D5°	5	10	-	35	-	10	5
	D10°	-	-	10	-	10	-	-
vertical angle sample no. 1	U10°	-	-	41.81	-	39.79	-	-
	U5°	18.58	40.87	-	80.19	-	38.95	14.93
	H	-	42.34	81.21	101.7	69.37	40.47	-
	D5°	18.06	37.85	-	55.15	-	37.67	15.28
	D10°	-	-	37.08	-	37.24	-	-
vertical angle sample no. 2	U10°	-	-	29.58	-	32.26	-	-
	U5°	15.60	28.79	-	81.30	-	31.00	16.35
	H	-	29.45	55.06	93.59	67.30	30.56	-
	D5°	15.26	26.38	-	41.88	-	29.64	16.57
	D10°	-	-	26.47	-	26.46	-	-

	sample no. 1	sample no. 2	allowable maximum	required minimum
maximum intensity [cd]	113.6	112.0	500	50
minimum intensity in the fields defined in Annex 1 of the Regulation [cd]	0.857	0.846	-	0.3

Manufacturer : Shangyu Groupstar Electric Appliance Co., Ltd.  
 Type : GS-LTL2010

2.5. Illuminating surface : Vertical and horizontal outlines of the illuminating surface of the light-signalling device in relation to the centre of reference and in accordance with Annex 3 of the Regulation No. 48

Definition of the illuminating surface of the device

⊕ centre of reference

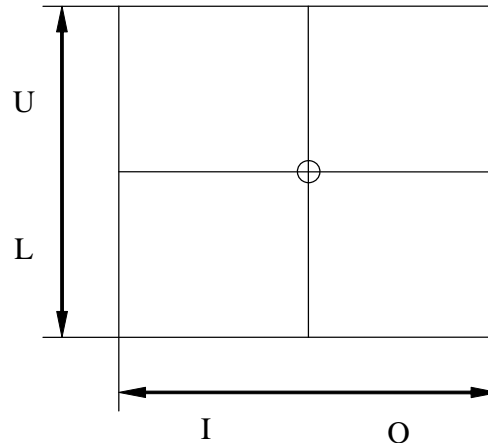

function	upper boundary (U) [mm]	lower boundary (L) [mm]	inner boundary (I) [mm]	outer boundary (O) [mm]
rear direction indicator lamp	24	24	21	21

2.6. Explanatory note : This report describes the examination of the rear direction indicator lamp as a part of a lamp device.

For the examination of the other lamp of the device, refer to the following report:

Type of lamp : rear position and stop lamp  
 Test Report No. : 87-R7-142/13

Manufacturer : Shangyu Groupstar Electric Appliance Co., Ltd.  
Type : GS-LTL2010

---

### 3. Remark concerning tested object(s)

All versions of the lamps as stated in the information document are covered with the tested version(s) and test object(s) respectively.

### 4. Appendices

0 List of modifications

Information folder no. : GS-LTL2010-00

### 5. Statement of conformity

The information folder and the type described there comply with the requirements in the above mentioned regulation.

The test laboratory is accredited for the above mentioned tests by the RDW, Vehicle Technology and Information Centre, the Netherlands:

Designation Number: RDW-99050014-06.

The test report comprises the pages 1 to 7 and shall not be reproduced except in full without the written approval of the test laboratory.

Engineering Center Guangdong, February 3, 2013  
ND/HH



B.S.M.E. N. Deng



Manufacturer : Shangyu Groupstar Electric Appliance Co., Ltd.  
Type : GS-LTL2010

---

**List of modifications**

**Appendix 0**

Correction of : ---

Modification of : ---

Addition of : ---

Deletion of : ---